

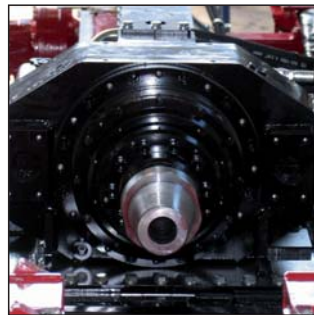

EM Class

EGT 

EM Class



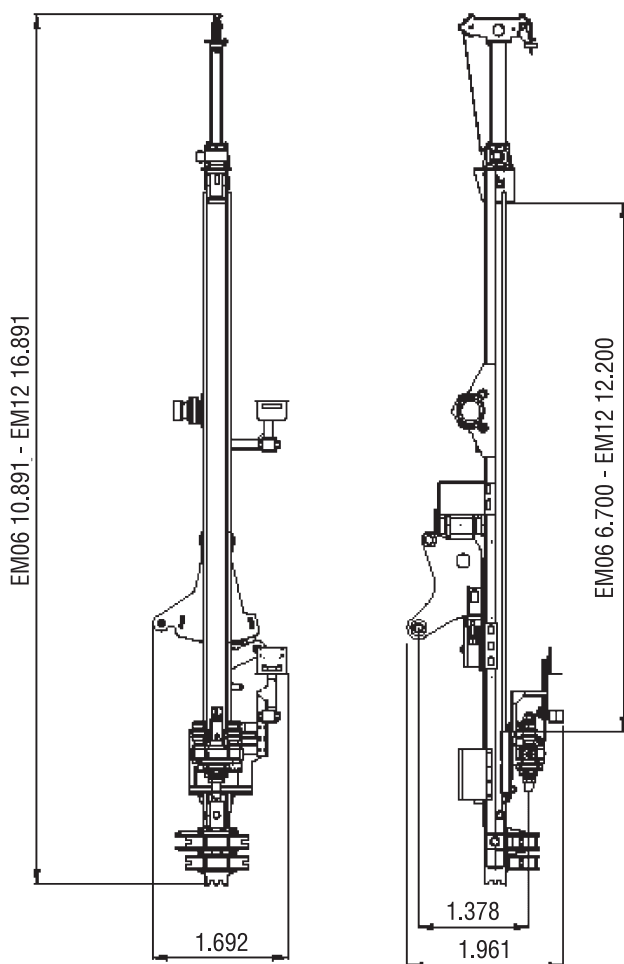

EM Class

Testa di rotazione disponibili

coppia/giri (max)	torque/spindle speed (max)	Nm/rpm	15.000/140
coppia/giri (max)	torque/spindle speed (max)	Nm/rpm	32.000/80
coppia/giri (max)	torque/spindle speed (max)	Nm/rpm	50.000/25

Available Rotary head

Mast

tipo	type		modular
corsa rotary (base)	basic rig rotary stroke	EM06	mm 6.700
corsa rotary max	max rotary stroke	EM12	mm 12.200

Mast

Verricello principale

forza di tiro (max)	line pull (max)	N	17.500
---------------------	-----------------	---	--------

Main winch

Verricello opzionale

forza di tiro (max)	line pull (max)	N	21.000
---------------------	-----------------	---	--------

Optional winch

Morse disponibili

diametro passaggio (min-max)	clearance (min-max)	mm	45-220
diametro passaggio (min-max)	clearance (min-max)	mm	58-320

Available clamp device

Caratteristiche tecniche soggette a modifiche senza preavviso. La diffusione su scala mondiale del prodotto qui illustrato impone, per le differenti normative l'utilizzo di immagini ed illustrazioni puramente indicative, quindi non impegnative.

Specifications subject to change without notice. The diffusion in the whole world of the product illustrated hereby imposes, because of the different norms, the use of indicative - hence not binding - images and illustrations.



EM Class

E.G.T. srl

Home office
Via Tadino 52, 201124 - Italy

Operation
Via Berna 1 - 43010 Loc. Bianconese Fontevivo
Parma, Italy
Tel.: +39 0521 618521
P.IVA: 08583260966

info@egt.it
www.egt.it