



WD20

EGT

WD20



I modelli della **WD Class** sono dedicati principalmente alla perforazioni per la ricerca idrica, sono realizzati in varie versioni e allestimenti: montaggio su autocarro o carro cingolato, tiro fino a 550.000 N, testa singola o doppia, coppia rotary fino a 50.000 Nm., rotary dedicate ai carotaggi, pompa fanghi, compressore aria.

Sono inoltre disponibili personalizzazioni delle macchine in funzione delle esigenze di ogni cliente.

***WD Class** models are mainly designed for water well drilling. Units are available with different configuration: truck or crawler mounted, pull-back force up to 550.000 N, single or double head, rotary head torque up to 50.000 Nm, specialized coring rotary heads, mud pump, air compressor.*

Further drill rig customized options are available to satisfy the various client needs.

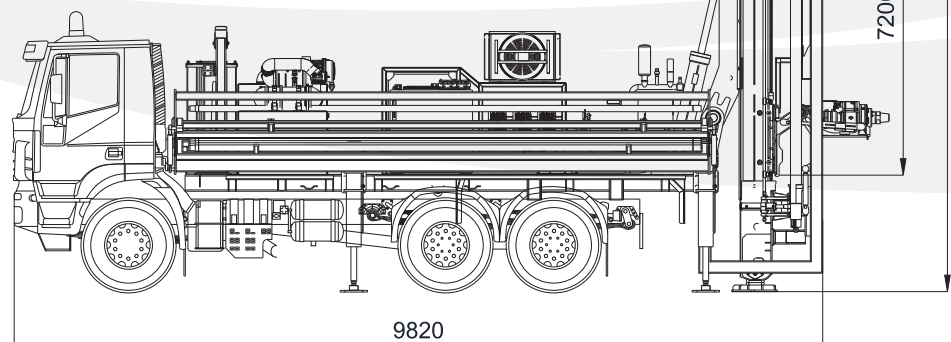
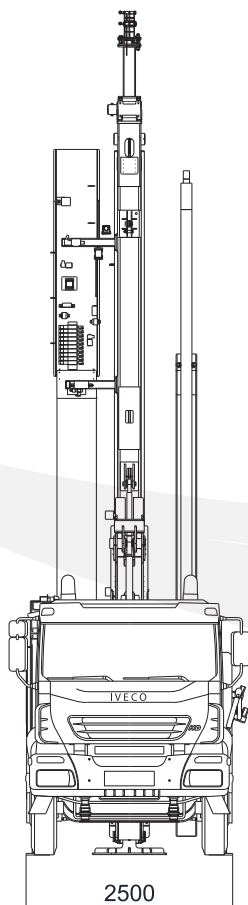

Mast		Mast		
Tipo	Type			Monolitico/monolithic
Corsa rotary (base)	Basic rig rotary stroke	mm		7200
velocità manovra rotary	Rotary travel speed	m/min		40
Tiro-spinta	Pullback (pulldown)	N		200.000 (130.000)
Testa di rotazione disponibili		Available Rotary head		R002700RH
1 ^a marcia	1 st gear	Nm/rpm		27.000 @ 30
2 ^a marcia	2 nd gear	Nm/rpm		18.400 @ 45
3 ^a marcia	3 rd gear	Nm/rpm		13.500 @ 65
4 ^a marcia	4 th gear	Nm/rpm		9.200 @ 100
Motore principale		Deck engine		
Marca e modello motore	Engine make / model			IVECO CURSOR 9
Potenza motore	Engine power	hp @ rpm		354 @ 2200
Portata olio	Oil flow	l/min		353
Capacità serbatoio olio	Oil tank	L		600
Capacità serbatoio gasolio	Fuel tank	L		200
Pompa duplex		Duplex mud pump		
Portata massima	Max flow	lt/min		1.692
Pressione massima	Max pressure	bar		17
Verricello principale		Main winch		
Forza di tiro (max)	Line pull (max)	N		70.000
Velocità fune (max)	Rope speed (max)	m/min		45
Diametro fune (max)	Rope diameter (max)	mm		22
Verricello servizio		Service winch		
Forza di tiro (max)	Line pull (max)	N		20.000
Velocità fune (max)	Rope speed (max)	m/min		40
Diametro fune (max)	Rope diameter (max)	mm		10
Morse disponibili		Available clamp device		
Diametro passaggio (min-max)	Clamping range	mm		80 - 450
Forza di serraggio	Clamping force	N		330.000
Coppia di svitamento	Clamping torque	Nm		60.000
Autocarro		Truck		
Tipo	Type			6 x 4
Modello	Model			IVECO T WAY 6X4
Passo	Wheelbase	mm		4500
Motore	Truck engine			CURSOR 13
Potenza motore	Diesel engine power	hp		430
Cambio	Gear box			ZF ECOSPLIT
Modello cambio	Gear box model			16 S 2220 TO
Rapporti cambio	Gear	nr		16
Larghezza	Width	mm		2500
Massa totale (allestimento base)		Mass (basic configuration)		kg
				24.000
Allestimenti opzionali		Optional configuration		
Pompa schiuma triplex	Foam pump water pump	lt min/bar		100/50
Compressore aria	Air compressor max flow/pressure	m³/bar		28,6/25

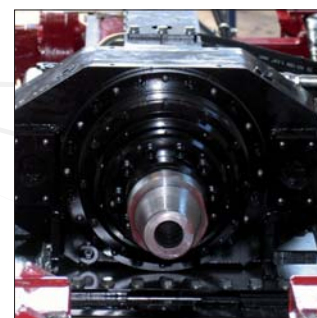

Caratteristiche tecniche soggette a modifiche senza preavviso. La diffusione su scala mondiale del prodotto qui illustrato impone, per le differenti normative l'utilizzo di immagini ed illustrazioni puramente indicative, quindi non impegnative.

Specifications subject to change without notice. The diffusion in the whole world of the product illustrated hereby imposes, because of the different norms, the use of indicative - hence not binding - images and illustrations.



WD20

E.G.T. srl

Via Tadino 52, 201124 Milano - Italy

Tel.: +39 800.547.999

P.IVA: 08583260966

info@egt.it
www egt.it